

HSR-JR630-1800

V1.0



HSR-JR630-1800 6

HSR-JR630-1800

“ ” “ ”

1.1	3
1.1.1	3
1.1.2	5
1.2	8
1.3	9
2.1	10
2.2	11
2.3	12
2.3.1	12
2.3.2	13
2.4	16
2.5	17
2.6	18
3.1	19
3.1.1	19
3.1.2	19
3.1.3	20
3.1.4	3	20
3.2	20
3.3	21
3.4	21
3.4.1	21
3.4.2	22
3.4.3	J1/J2/J3	22
3.4.4	25
3.5	25
3.5.1	25
3.5.2	26
4.1	28
4.2	29
4.3	29

4.3.1	29
4.3.2	30
4.4	30
4.5	31
5.1	32
5.2	32
5.3	32

1

1.1







1.1.1

1

2

3

4

2

1

1

1

5

6

“ ”

7



- 1
- 2
- 3

“ ” “ ”

“ ” “ ”

“ ” “ ” “ ”

“ ”

- 1
- 2
- 3
- 4
- 5
- 6
- 7
- 8
- 9

“ ” “ ” “ ”

”



危险



危险

“ ” “ ”



危险

,

1.1.2

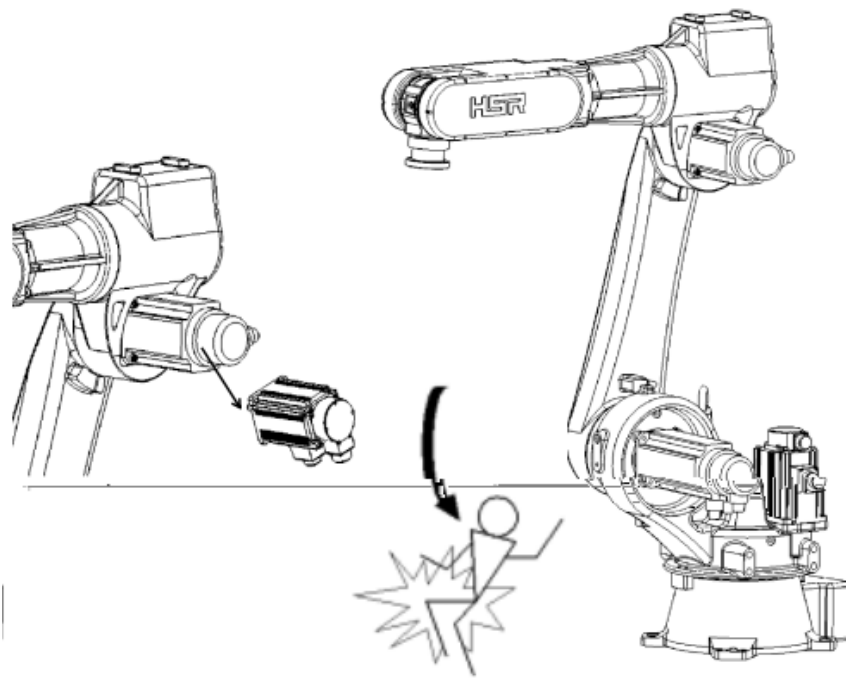

...



Compact flash card







注意



注意



注意



注意

100%



注意

1.2



注意



注意

1.3



注意



注意



注意



注意



注意

2.2

6

6

2.1



2.1

2.3

	280kg
	IP53
	690mm × 411mm × 890mm -
	91kg

2.2 HSR-JR630-1800

	°	
J1	0°	±155°
J2	-90°	-175°/+70°
J3	180°	+45°/+260°
J4	0°	±360°
J5	90°	±125°
J6	0°	±360°

2.4

2.3/2.4

4

M10

3m

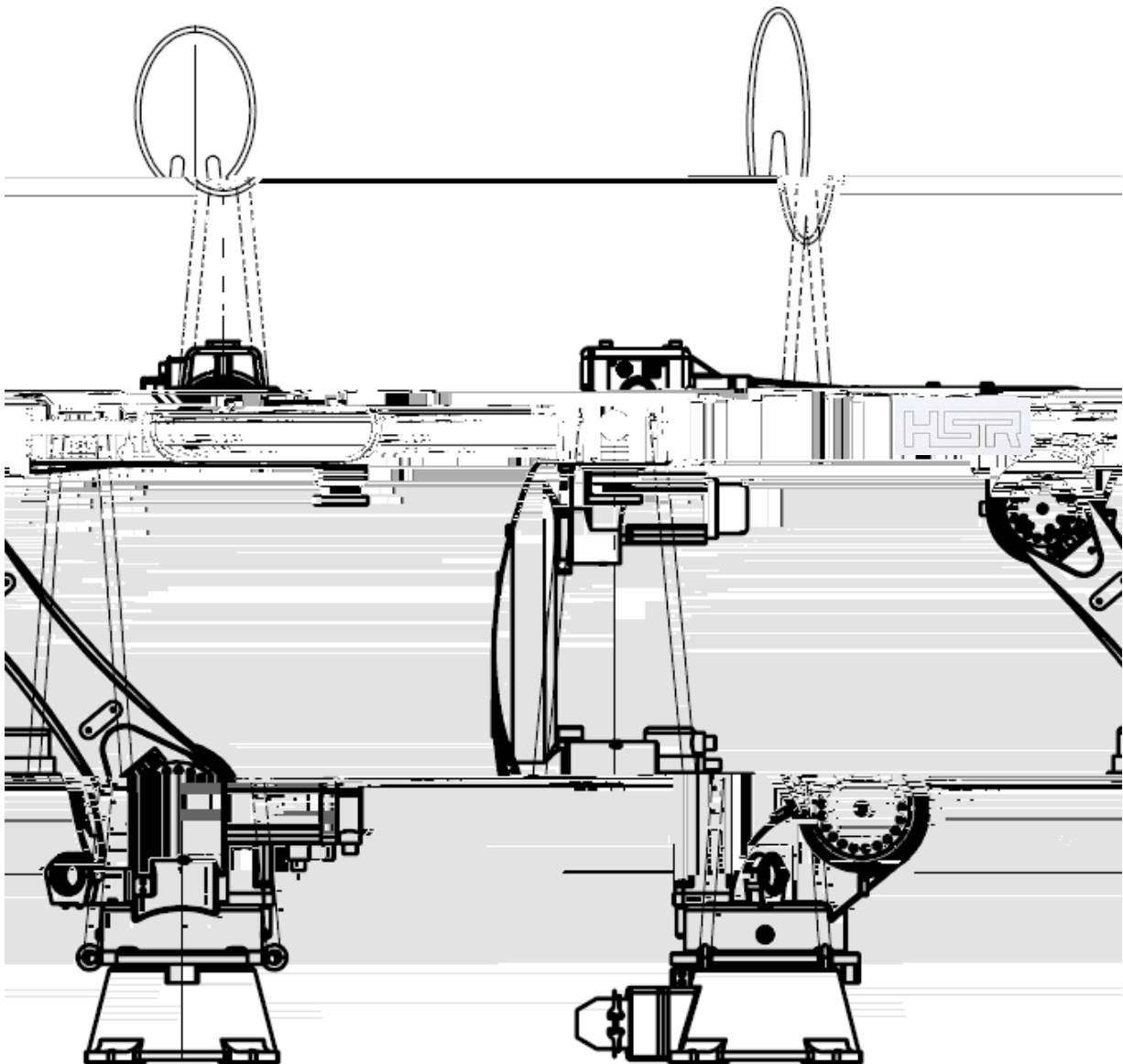

2.3/2.4

2.5

1)

4 M16

2.5

2)

2.5

2.6

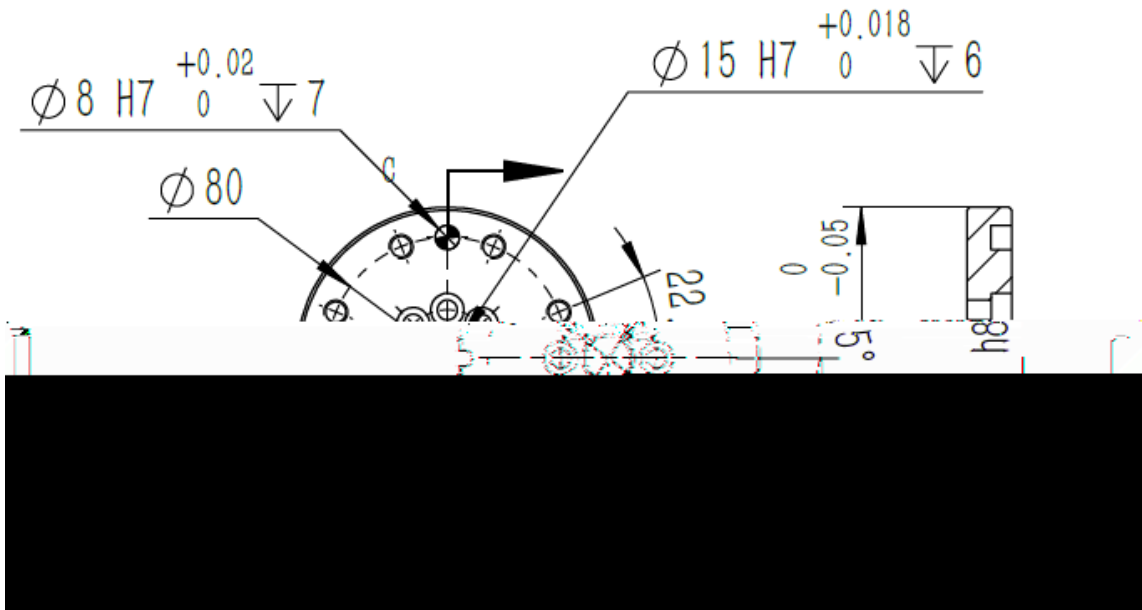

2.6

2.6



注意

1

2.3

HSR-JR630-1800	30kg

2

2.4

	J4	J5	J6
HSR-JR630-1800	84.8NM	84.8NM	45NM

3

2.5

	J4	J5	J6
HSR-JR630-1800	3.92kg.m ²	3.92kg.m ²	1.3kg.m ²

3

40 000 8

8

3.1.3

3.3

1		
2		

3.1.4 3

3.4 3

4 5 6	

1

2

3.2

3.5

1		5	J4
2	J1	6	J5
3	J2	7	
4	J3	8	



注意

3.3

3.6

	HSR-JR630-1800	()	
J1	857ml		

J2

580ml

MOLYWHITE RE
NO.OO

40ml/10

8

9 3.4.4

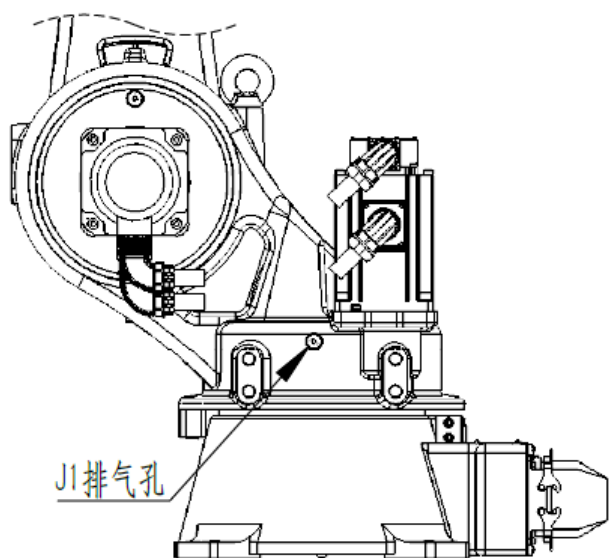

3.1

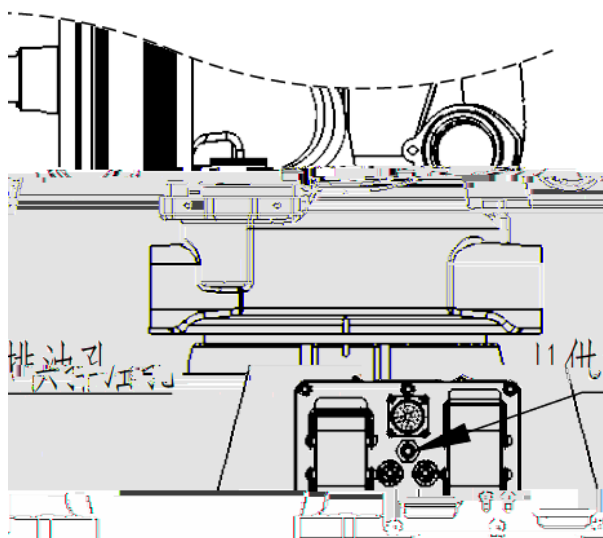

J1

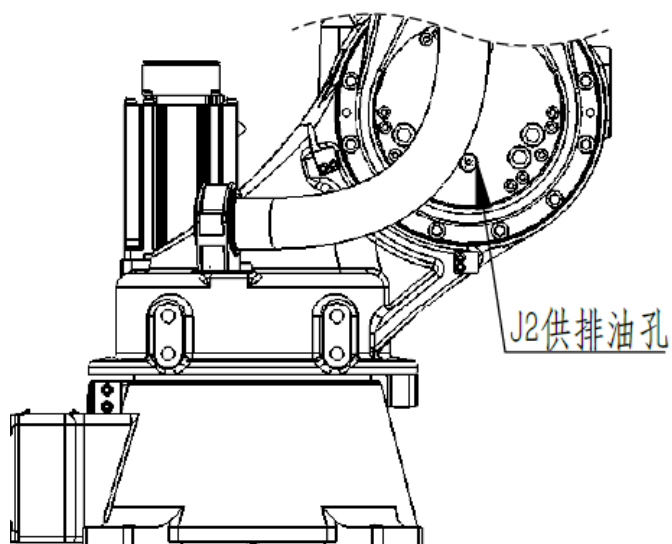

3.2

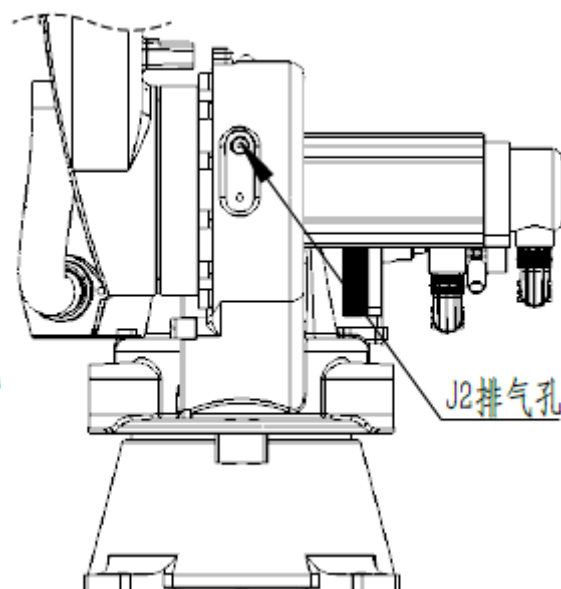

J2

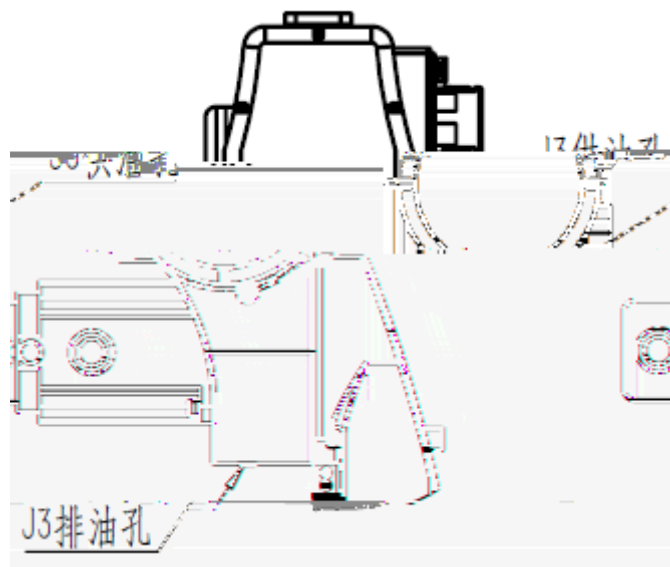

3.3

J3

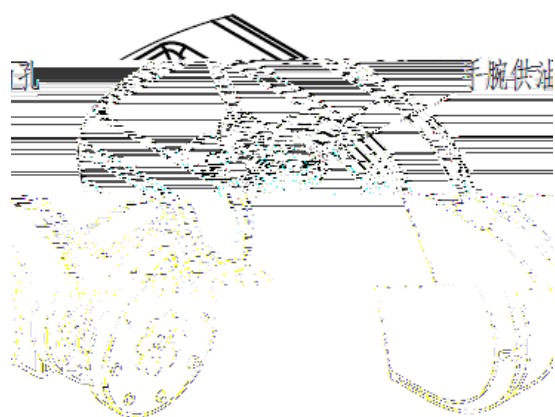

3.4.4

J1 ±30° J2/J3 ±10° 20

2

3.5

3.5.1

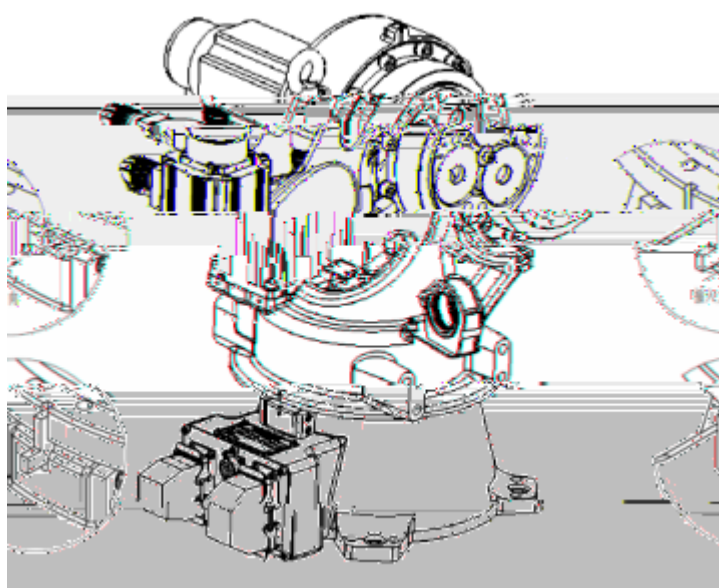

3.4

3.4

U

U



注意

3.5.2

3.5-3.8

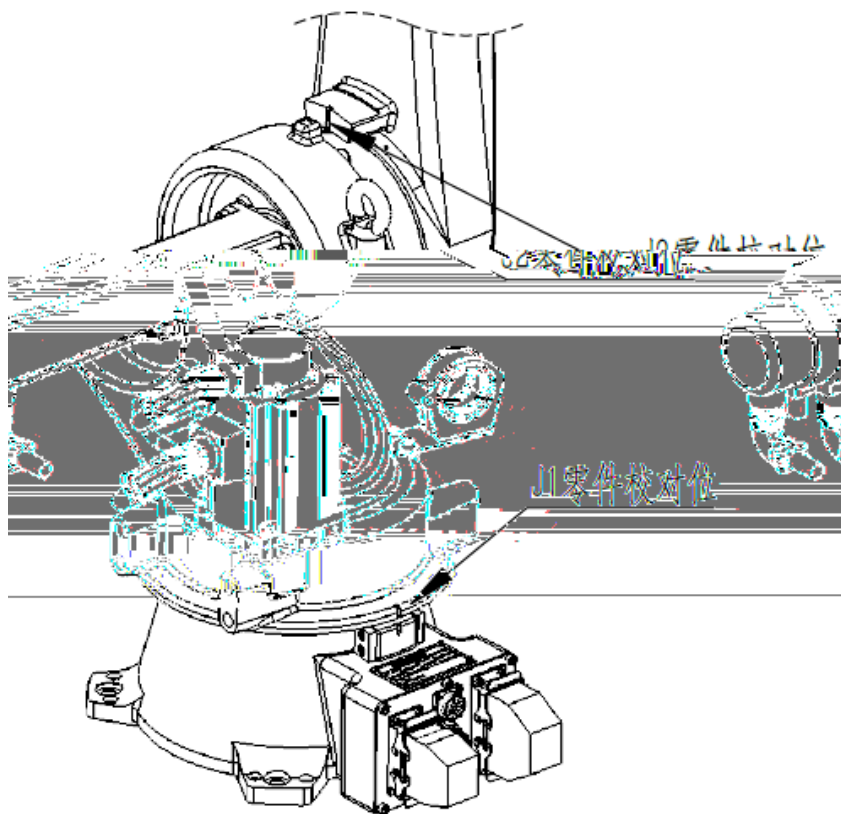

3.5 J1/J2

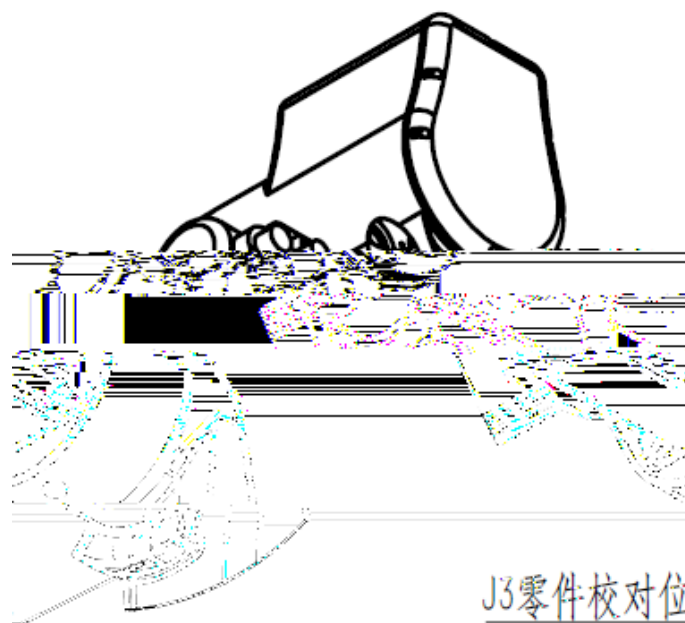

3.6 J3

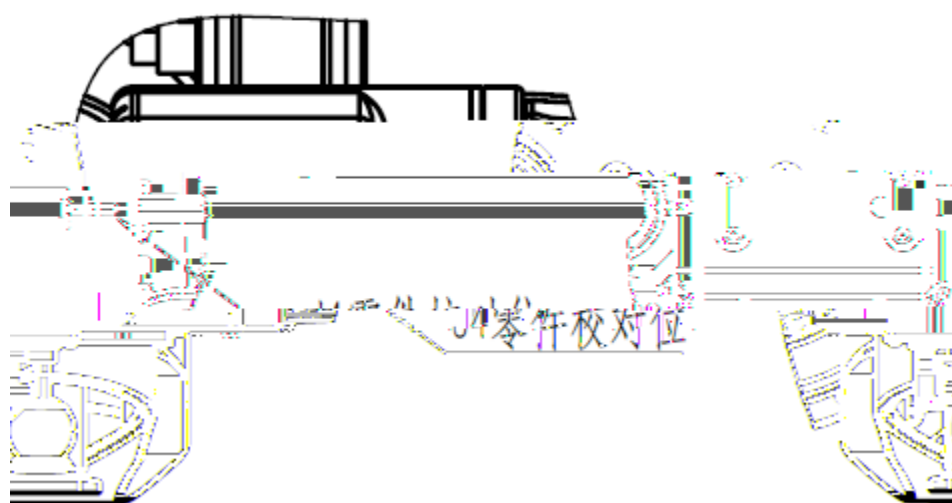

3.7 J4

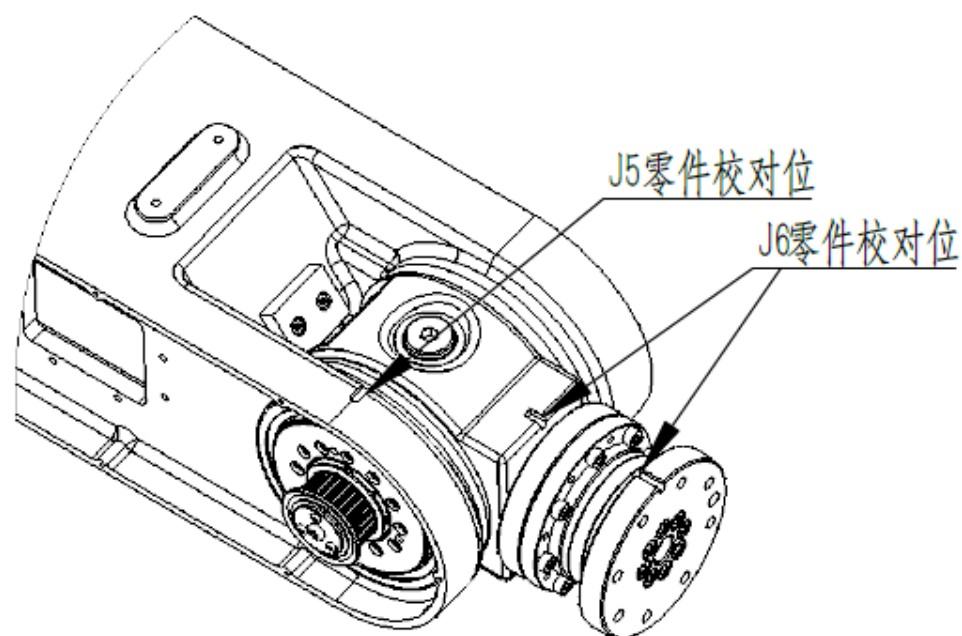

3.8 J5 J6

4

4.1

1

2

3

OFF

4

5

6

(2) (3) (4)

1

2

3

4.3

4.2

4.1

4.1

[1]		
[2]		
[3]		

[1]

[2]

[3]

4.3

4.3.1

1

1000ppm

5,000

1

2,500

10°

2

4.3.2

1

2

4.4

1)

2)

3)

4)

5)

6)

4.5

4.1 4.2

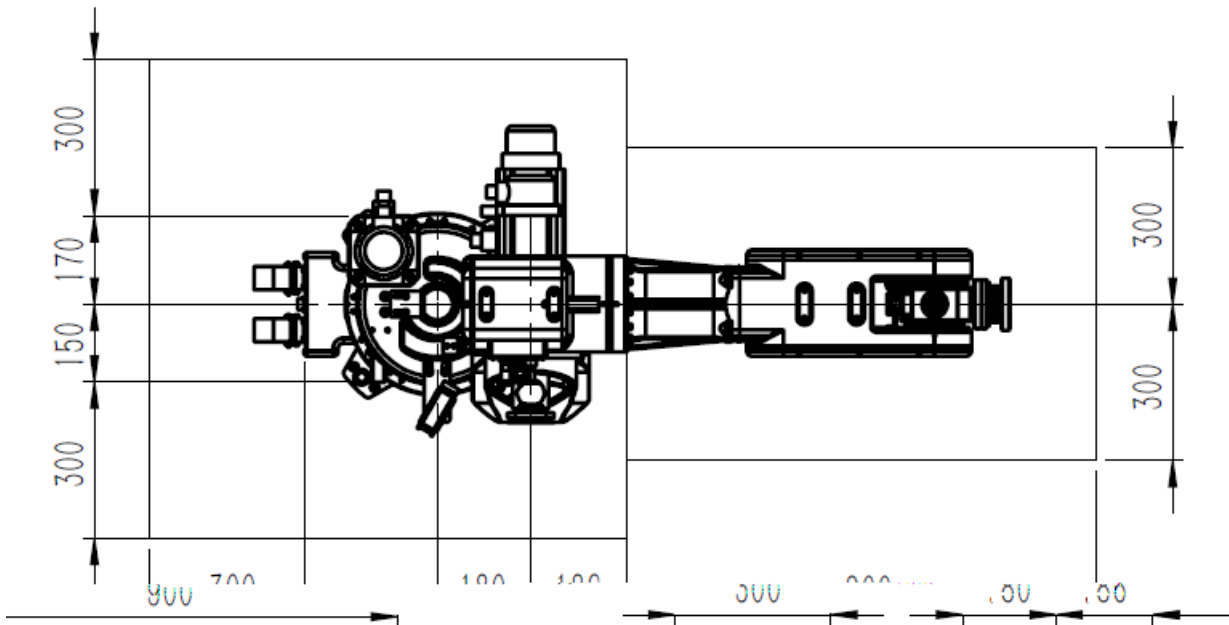

4.1 HSR-JR630-1800

5

5.1

A	3.5
B	3.5

5.2

	S5M-390-15	3.1.3
	S5M-475-15	3.1.3
	S5M-690-15	3.1.3

5.3

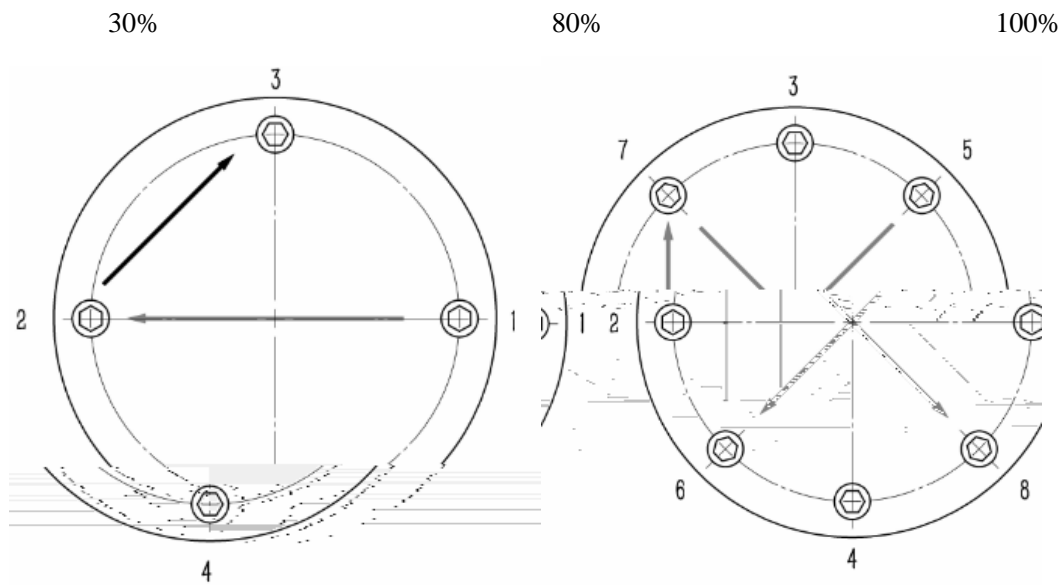

- 1
- 2
- 3

2

4

5

5-1

	8.8		12.9	
	Nm	Nm	Nm	Nm
M3	1.2	1.1 1.5	2	1.6 2.2
M4	2.5	2.2 3.5	4.8	3.8 5.7
M5	5	3.2 4.4	9.3	8.4 10.2
M6	8	7.4 11.2	16	15 18
M8	20	16 26	42	35 53
M10	40	36 52	80	74 88
M12	75	61 94	129	120 138
M14	120	97 150	205	195 220
M16	200	170 230	380	320 425

8.8

1

2

3



5 69

400714

023-88026878

service_cq@hzncc.com

19

528234

0757-81991717

service_fs@hzncc.com



中文官网: www.huasrobotics.com

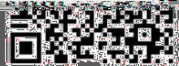

华数机器人



